

Technical Specification for Schools: Interactive Whiteboards

| | |
|---|--|
| Produced By: | Leonard Veenendaal Technical Services Manager |
| Reviewed By: | Lee Brandrith Senior Network/Electrical Engineer |
| Team: | ICT Technical Services |
| Date: | May 2008 |
| Version | 3 |
| www.ccceducation.net Resource ID | 3850 |

Contents

| | | |
|-------|--|---|
| 1.1 | Introduction | 3 |
| 1.2 | Contacts | 3 |
| 2.0 | Health and Safety | 3 |
| 3.0 | Technical Specifications | 4 |
| 3.1 | Interactive Whiteboard | 5 |
| 3.2 | Projector | 5 |
| 3.2.1 | Brightness of projector | 5 |
| 4.0 | Installation | 6 |
| 4.1 | Height of projector | 6 |
| 4.1.1 | Ceiling mount | 6 |
| 4.2 | Security cage | 6 |
| 4.3 | Electrical installation | 6 |
| 5.0 | General Use | 7 |
| 5.1 | Switching the projector on and off | 7 |
| 6.0 | Maintenance | 7 |
| 6.1 | Projector Maintenance | 7 |
| 7.0 | Useful contact information | 8 |
| 8.0. | Portal Links & searches | 8 |

It is vital that the process of planning, architect design and procurement is informed by consultancy from **Education ICT Service** to ensure:

- Data points are correctly positioned for all areas
- Ordering of NTL circuit is timely
- Specifications for resource purchases are completely up to date

Additionally, **Education ICT Service** offer new schools or schools that are having extensions or being refurbished a package that provides project management to oversee curriculum, MIS and technical issues during build through into the life of the school. For further information visit



www.ictsla.ccceducation.net

1.1 Introduction

The purpose of this document is to outline the technical requirements and care and maintenance of Projectors and Interactive Whiteboards for schools.

1.2 Contacts

Leonard Veenendaal
Technical Services Manager
Education ICT Service, Godmanchester, PE29 2HJ

 **phone:** 01480 376655
 **fax:** 0871 661 6638
 **e-mail** leonard.veenendaal@cambridgeshire.gov.uk

2.0 Health and Safety

Users, teachers and pupils should be warned of the risk of deliberately looking into the light projected by the projector. Under no circumstances should pupils be left unsupervised when using projectors. Please refer to guidance distributed to all schools earlier in the year that **must** be displayed in classrooms where a digital projector is in use.

In order to maintain the projector in the manner described, **never** stand on a desk or chair – always use a step ladder appropriate for the height of the projector.

3.0 Technical Specifications

| | |
|---------------------|--|
| Picture size | 40 - 300 inch (aspect ratio 4:3) |
| PC compatibility | Resolution : 640 x 400 (Expand) - 1,024 x 768 (Real) - 1,280 x 1,024 (Compress) (XL5U) 640 x 400 (Expand) - 800 x 600 (Real) - 1,024 x 768 (Compress) (SL4SU) Sync on Green available |
| Video compatibility | NTSC / NTSC 4.43 / PAL (including PAL-M, N) / SECAM, PAL-60 Component Video (DVD/HDTV) (480i, 576i, 480p, 576p, 1080i, 720p) |
| Audio output | 2 W Mono |
| Speaker | Oval type (16 Ω 2 W) \times 1 |
| S-video input | Luminance signal: 1.0 Vp-p 75 Ω (negative sync.) Chroma signal: 0.286 Vp-p 75 Ω (burst signal) |
| Video input | 1.0 Vp-p 75 Ω (negative sync.) |
| Audio input | 300 mVrms, 10 k Ω or more |
| Analog RGB input | RGB: 0.7 Vp-p 75 Ω (negative sync.) Y _{PbPr} (Y _{CbCr}): Y:1.0 Vp-p (negative sync.) P _{bPr} (C _{bCr}):0.7 Vp-p HD/CS : TTL level (positive or negative) VD : TTL level (positive or negative) |
| Control connector | Serial (8-pin connector) RS-232C standards USB terminal |

Front projection

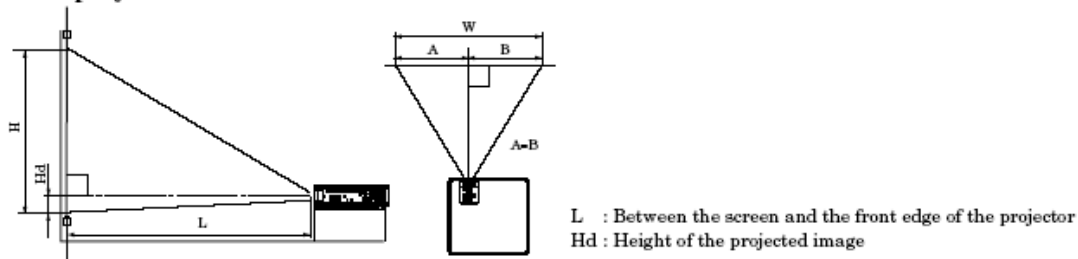

| Screen | | | | | | Distance from the screen : L | | | | Hd | |
|---------------|-----|-----------|-----|------------|-----|------------------------------|-----|---------------------|-----|------|------|
| Diagonal size | | Width : W | | Height : H | | Maximum zoom (WIDE) | | Minimum zoom (TELE) | | | |
| inch | cm | inch | cm | inch | cm | inch | m | inch | m | inch | cm |
| 40 | 102 | 32 | 81 | 24 | 61 | 49 | 1.3 | 60 | 1.5 | 2.4 | 6.1 |
| 60 | 152 | 48 | 122 | 36 | 91 | 75 | 1.9 | 91 | 2.3 | 3.6 | 9.1 |
| 80 | 203 | 64 | 163 | 48 | 122 | 101 | 2.6 | 121 | 3.1 | 4.8 | 12.2 |
| 100 | 254 | 80 | 203 | 60 | 152 | 126 | 3.2 | 152 | 3.9 | 6.0 | 15.2 |
| 150 | 381 | 120 | 305 | 90 | 229 | 191 | 4.8 | 229 | 5.8 | 9.0 | 22.9 |
| 200 | 508 | 160 | 406 | 120 | 305 | 255 | 6.5 | 306 | 7.8 | 12.0 | 30.5 |
| 250 | 635 | 200 | 508 | 150 | 381 | 319 | 8.1 | 383 | 9.7 | 15.0 | 38.1 |
| 300 | 762 | 240 | 610 | 180 | 457 | 383 | 9.7 | - | - | 18.0 | 45.7 |

- The above figures are approximate and may be slightly different from the actual measurements.

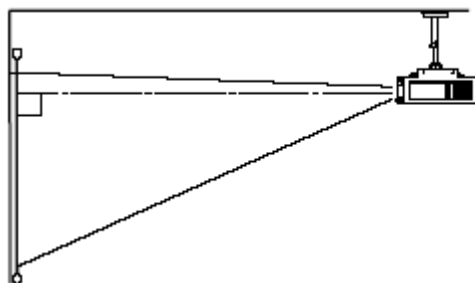

3.1 Interactive Whiteboard

SMART Board™ 560

Wall Mounted

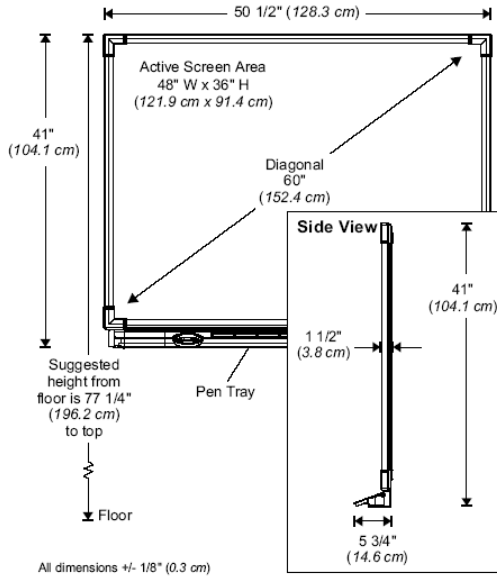

Floor Stand (optional)

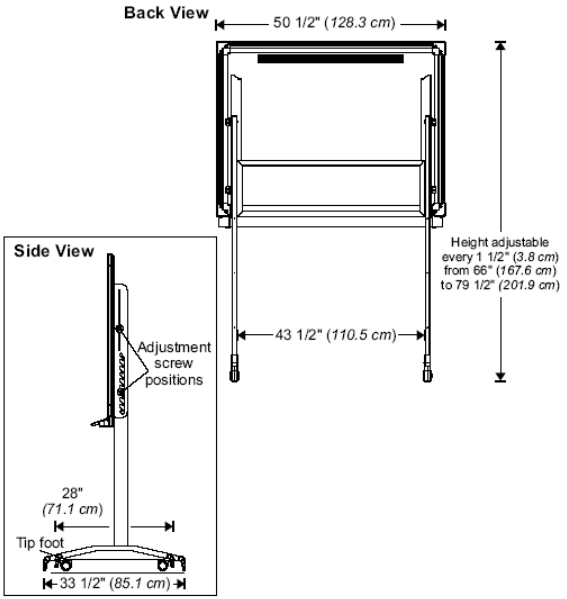

SMART Board 580

Wall Mounted

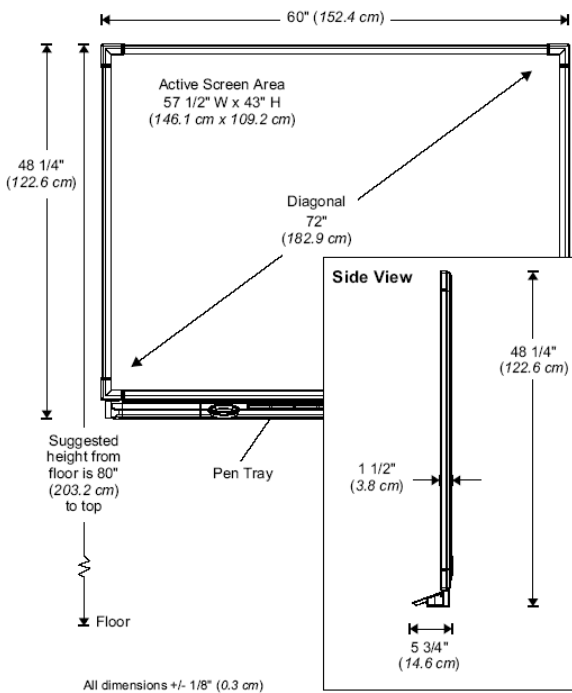

Floor Stand (optional)

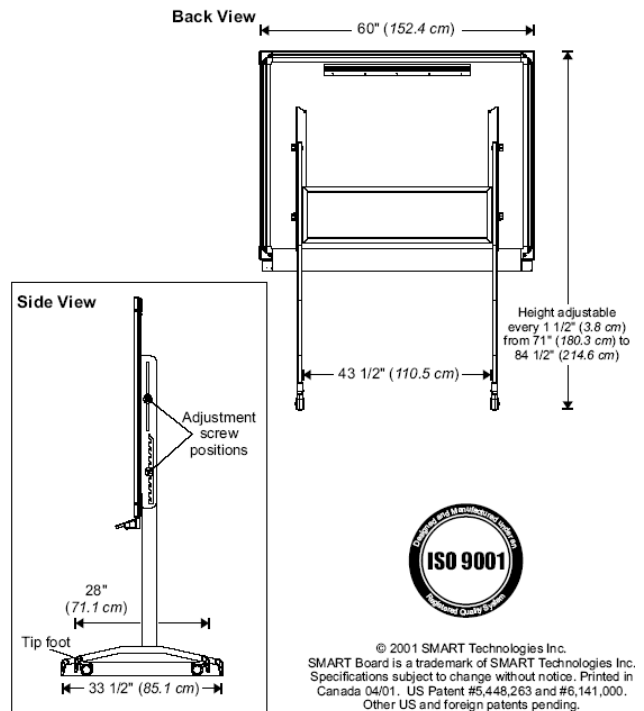

3.2 Projector

3.2.1 Brightness of projector

The **maximum number of lumens** recommended by Becta for classroom use is **1500**. Although every classroom is different, a 1500 lumens projector is bright enough

for most classrooms. If this is not the case, you should fit curtains or blinds to block out ambient light, rather than buying a brighter projector. Be aware that some projectors have high and low settings – you should check that the setting you are operating is at a maximum of 1500 lumens.

4.0 Installation

4.1 Height of projector

Ideally, the projector lens should be in line with the top of the Interactive Whiteboard as this will produce an image that fits the interactive whiteboard perfectly. However, obvious health and safety considerations dictate that the projector should be well above potential head height and as a guide we recommend that the projector is mounted **no lower than 6 feet and 6 inches (2 metres)**.

4.1.1 Ceiling mount

When classrooms are surveyed for the installation of a projector you should ask about how the projector will be fixed to the ceiling. You should be provided with details dependent on the type of ceiling material in your school. Companies should have method statements to cover this. In some circumstances, where ceilings are weak or contain potentially harmful materials, a boom solution can be utilised.

A data outlet with a fused spur electrical point at the appropriate position in the ceiling needs to be installed to service and manage all ceiling mounted projectors.

4.2 Security cage

You may decide to fit additional security devices such as security cages for the projectors which will make theft of the units much more difficult. If this is the case, ensure that the bottom of the cage is well above head height, at least 6 feet 6 inches from the ground. Our experience is that the investment in such security devices is a good long-term strategy.

If you are ever unsure about any of the above, either refer to your property manager or Education ICT Service for further advice.

4.3 Electrical installation

All projectors require a power socket. **You should not** use an extended power cable simply plugged in to an existing socket in the classroom. You **must use a qualified electrician who is at least ECA or NICEIC approved** to install a switched socket adjacent to the projector, accommodating the plug with flexible cable to the projector. In exceptional circumstances, depending on building construction, the lead from the projector could be connected in to a fused spur. A controlling fused spur should be located adjacent to the white board, somewhere out of reach of children, for isolating the projector. This is so that the projector's electricity supply can be isolated from the rest of the mains sockets in an emergency as described above, when cleaning or during school holidays. Secondary schools may like to consider the use of a key switch to stop the projector being isolated by students and thus affecting the life of the bulb.

5.0 General Use

5.1 Switching the projector on and off

Always use the remote control for powering up and powering down the projector. If the remote is unavailable, the buttons/features on the remote (including the standby/on button) are duplicated on the projector itself. Because the projector is ceiling mounted (and therefore mounted upside down), the buttons should be visible as you look up. Use the buttons on the projector as a last resort – contact with the projector can cause misalignment of the projector. A rule of thumb is that the projector should be switched to standby if it will not be used for longer than 20 minutes. Standby mode on the projector uses very little electricity and ensures the fan operates when necessary to maximise bulb life.

There is an isolation switch located either on the wall adjacent to the projector or on the ceiling itself. This needs to be **switched off overnight and certainly during half-terms or school holidays**, when the projector is not going to be used for a long time. Remember to allow the bulb to cool before isolating the projector. The isolation switch should also be used in emergencies or when cleaning the projector.

Do not switch the projector off at the mains when it is in use unless the unit is smoking, dislodged from the mount or if it has been exposed to water (i.e. only in emergencies!). Switching the projector off at the mains or isolation switch without allowing the fans to cool the bulb (90 seconds) results in damage to the bulb that **is usually not** covered by the manufacturer's warranty. The cost of a new bulb, which can be as much as £300 + VAT, in this instance would be the responsibility of the school.

If you are having unassociated electrical work carried out in your school, **contractors should be advised** not to turn off the power or circuits without checking that all lamps are off and cool.

6.0 Maintenance

6.1 Projector Maintenance

Please refer to the instruction manual provided by the manufacturer for detailed instructions regarding the following:

General advice for maintenance:

- **Always isolate the projector and allow the bulb to cool down** before cleaning the projector or replacing the bulb
- Cleaning air filters – usually the warranty will ask that filters are cleaned at regular intervals – this might be once a month or more frequently. **Failure to clean filters in line with manufacturers advice can invalidate guarantees**, as one or two of our schools have already discovered. Filters are normally cleaned by using a standard vacuum cleaner hose, but again, please check the manuals for details

- Clean the projector lens (if required) with a clean, lint-free cloth. You should ***never touch the lens during cleaning***
- Check that the bulb setting on the projector is at low or standard. Most projectors have an option for a high setting. This increases the power of the beam and provides a crisper image, useful when playing video, but this ***dramatically reduces the life of the bulb***. The projector manual will provide details of how to check the setting – usually this is accessed via the menu option on the remote
- Maintain visual checks of the fixing and wiring to the projector. If at any time these appear to be coming loose this should be reported ***immediately*** and the projector isolated until checked by a suitably qualified individual

The above advice ***should always*** be used in collaboration with the advice provided by the manufacturer of the projector.

7.0 Useful contact information

ICT Service Main Office

42 West Street, Godmanchester PE29 2HJ

✉ ict.service@cambridgeshire.gov.uk

☎ 01480 376655

ICT Service procurement team

Cambridge Road, Waterbeach

✉ sales@ict.cceducation.net

☎ 01223 566456

Staff

Leonard Veenendaal.

Technical Services Manager

✉ Leonard.veenendaal@cambridgeshire.gov.uk

8.0. Portal Links & searches

Additionally, **Education ICT Service** advice and guidance documents are available by visiting <http://www.icttid.cceducation.net> click on

- [Servers & Networking](#)
- [Broadband/CCN Documents](#)
 - [Schools CCN Information and Guidance](#) (PDF 225Kbs)
 - [Diagram Overview of the Schools CCN Network](#)
 - [Electrical Specification for School ICT Cabinets](#) (PDF 103 Kbs)